

BRFL60R190C

Rev.A Feb.-2023

DATA SHEET

描述 / Descriptions

TO-220FL 塑封封装 N 沟道 600V 超结工艺功率场效应管。

N-CHANNEL 600V Super-Junction Power MOSFET in a TO-220FL Plastic Package.

特征 / Features

低 $R_{DS(on)} \times Q_g$, 100%雪崩测试, 符合 ROHS 标准, 具有快恢复二极管, 无卤产品。

Very low $R_{DS(on)} \times Q_g$, 100%avalanche tested, RoHS compliant, with fast-recovery diode, HF Product.

用途 / Applications

用于开关电源, 不间断电源, 功率因素校正。

For switch mode power supply, uninterruptible power supply, power factor correction.

内部等效电路 / Equivalent Circuit

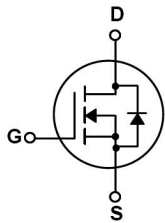

引脚排列 / Pinning

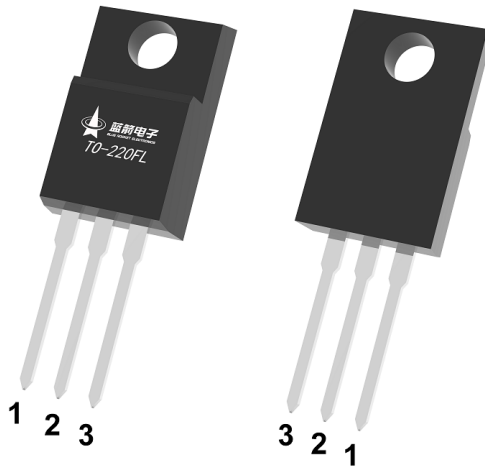

PIN1 : G

PIN 2 : D

PIN 3 : S

印章代码 / Marking

见印章说明

See Marking Instructions.

极限参数 / Absolute Maximum Ratings(Ta=25°C)

参数 Parameter	符号 Symbol	数值 Rating	单位 Unit
Drain-Source Voltage	V _{DSS}	600	V
Drain Current	I _D (T _c =25°C)	20	A
Drain Current - Pulsed	I _{DM}	60	A
Gate-Source Voltage	V _{GS}	±30	V
Single Pulsed Avalanche Energy	E _{AS}	405	mJ
Avalanche Current	I _{AS}	12.5	A
Power Dissipation	P _D (T _c =25°C)	34	W
Operating and Storage Temperature Range	T _J , T _{STG}	-55 to 150	°C
Junction-to-Case	R _{θJC}	3.6	°C/W
Junction-to-Ambient	R _{θJA}	80	°C/W

电性能参数 / Electrical Characteristics(Ta=25°C)

参数 Parameter	符号 Symbol	测试条件 Test Conditions	最小值 Min	典型值 Typ	最大值 Max	单位 Unit
Drain-Source Breakdown Voltage	BV _{DSS}	V _{GS} =0V I _D =250μA	600			V
Zero Gate Voltage Drain Current	I _{DSS}	V _{DS} =600V V _{GS} =0V T _J =25°C			5.0	μA
Gate-Body Leakage Current, Forward	I _{GSS}	V _{GS} =±30V			±100	nA
Gate Threshold Voltage	V _{GS(th)}	V _{DS} =V _{GS} I _D =250μA	2.5		4.5	V
Static Drain-Source On-Resistance	R _{DS(on)}	V _{GS} =10V I _D =10A		160	190	mΩ
Drain-Source Diode Forward Voltage	V _{SD}	V _{GS} =0V I _{SD} =1A T _J =25°C			1.2	V
Gate Resistance	R _g	V _{GS} = 0V f = 1.0MHz		3.5		Ω
Input Capacitance	C _{iss}	V _{DS} =100V V _{GS} =0V f=1.0MHz		1725		pF
Output Capacitance	C _{oss}			90		pF
Reverse Transfer Capacitance	C _{rss}			2.5		pF
Turn-On Delay Time	t _{d(on)}	V _{DS} =400V I _D =10A R _G =25Ω V _{GS} =10V		26		ns
Turn-On Rise Time	t _r			39		ns
Turn-Off Delay Time	t _{d(off)}			115		ns
Turn-Off Fall Time	t _f			32		ns

电性能参数 / Electrical Characteristics(Ta=25°C)

参数 Parameter	符号 Symbol	测试条件 Test Conditions	最小值 Min	典型值 Typ	最大值 Max	单位 Unit
Continuous Diode Forward Current	I_S			20		A
Total Gate Charge	Q_g	$V_{DS}=480V$ $I_D=10A$ $V_{GS}=10V$		38.2		nC
Gate-Source Charge	Q_{gs}			10		nC
Gate-Drain Charge	Q_{gd}			13		nC
Reverse recovery time	t_{rr}	$V_R=400V$, $I_F=10A$, $di_F/dt=100A/\mu s$		141		ns
Reverse recovery charge	Q_{rr}			0.85		uC

电参数曲线图 / Electrical Characteristic Curve

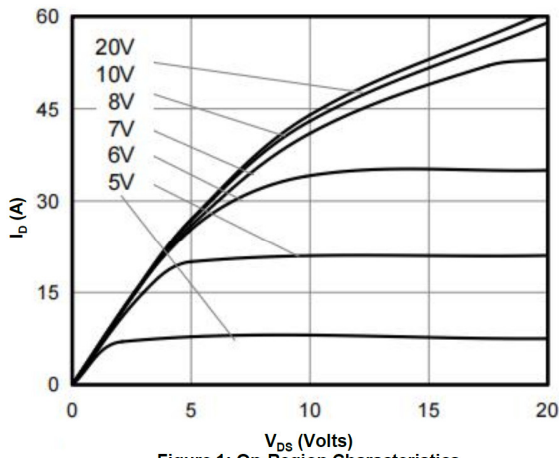

Figure 1: On-Region Characteristics

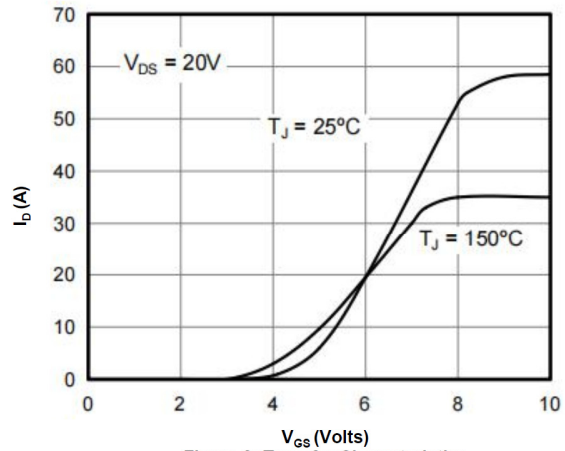

Figure 2: Transfer Characteristics

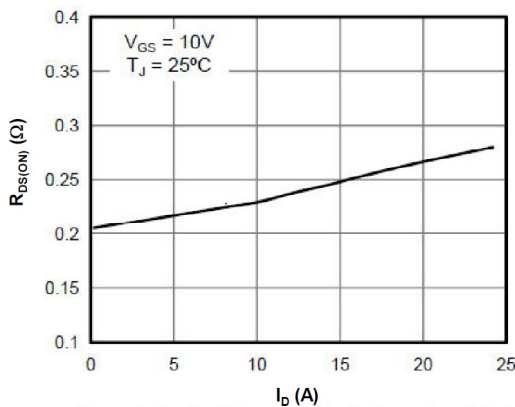

Figure 3: On-Resistance vs. Drain Current and Gate Voltage

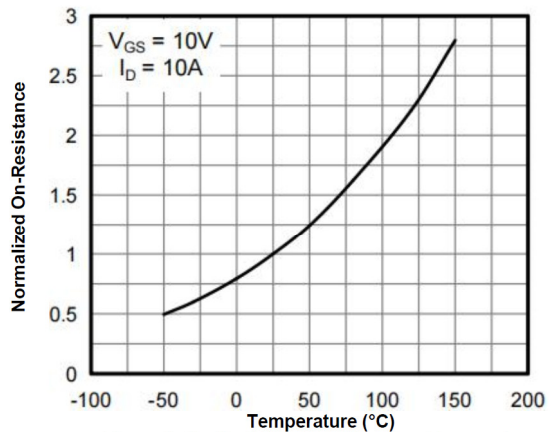

Figure 4: On-Resistance vs. Junction Temperature

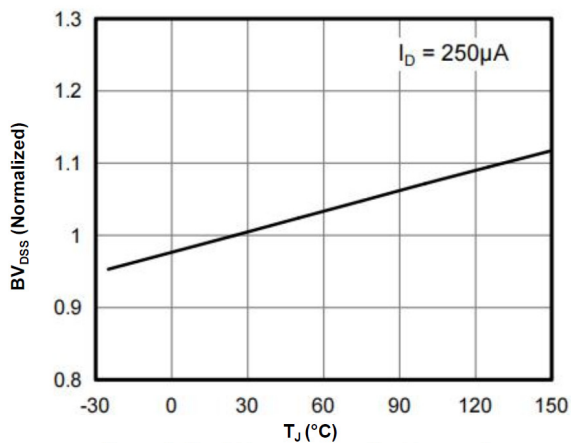

Figure 5: Break Down vs. Junction Temperature

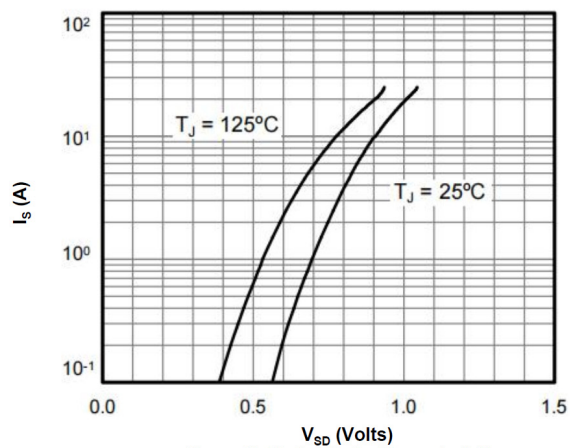

Figure 6: Body-Diode Characteristics

电参数曲线图 / Electrical Characteristic Curve

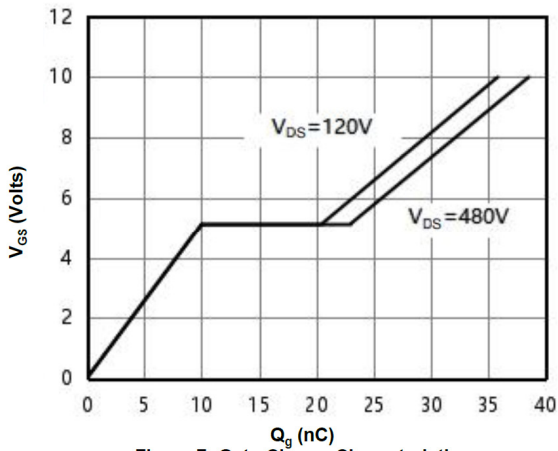

Figure 7: Gate-Charge Characteristics

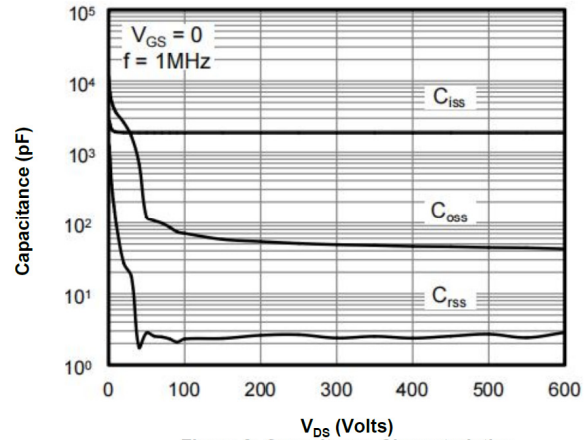

Figure 8: Capacitance Characteristics

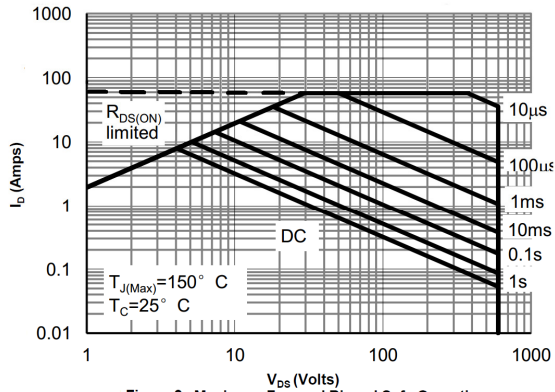

Figure 9: Maximum Forward Biased Safe Operating Area

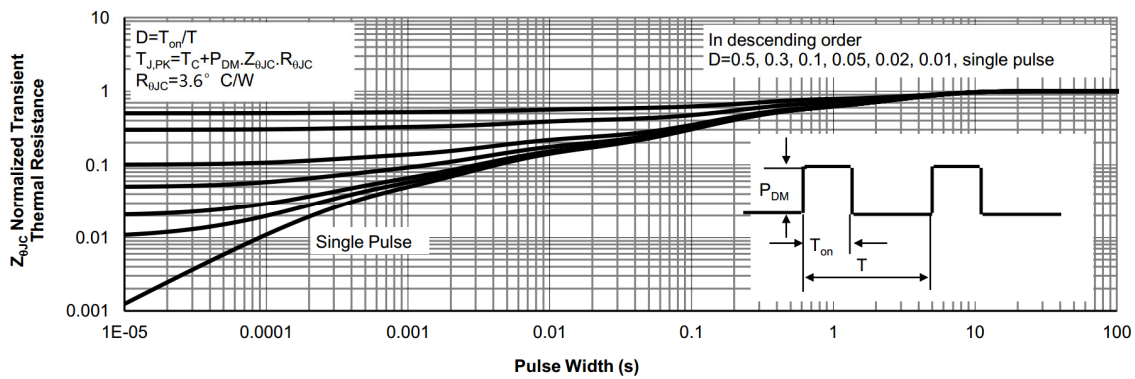
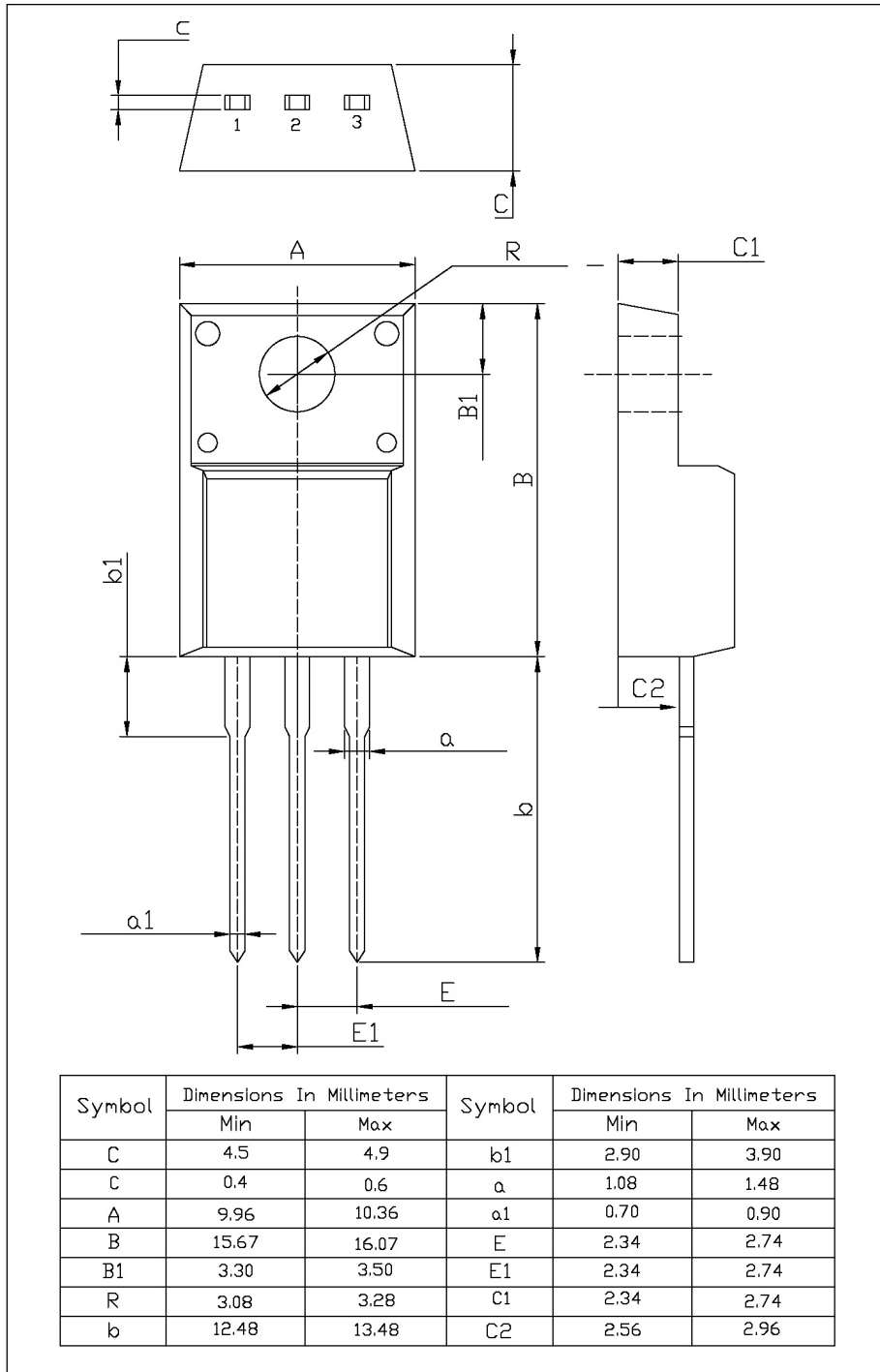

Figure 10: Normalized Maximum Transient Thermal Impedance

外形尺寸图 / Package Dimensions

TO-220FL

单位: mm



印章说明 / Marking Instructions

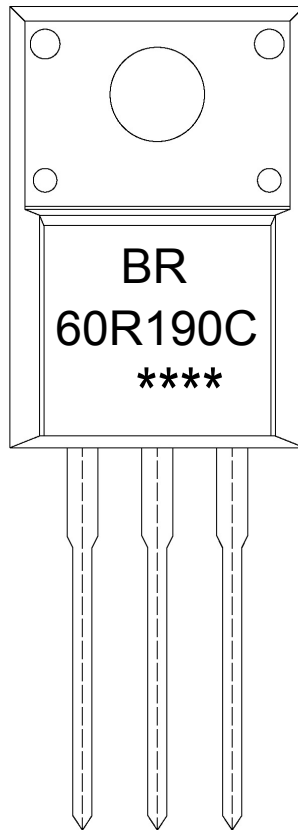

说明：

BR： 为公司代码

60R190C： 为型号代码

****： 为生产批号代码，随生产批号变化

Note:

BR: Company Code

60R190C: Product Type Code

****: Lot No. Code, code change with Lot No

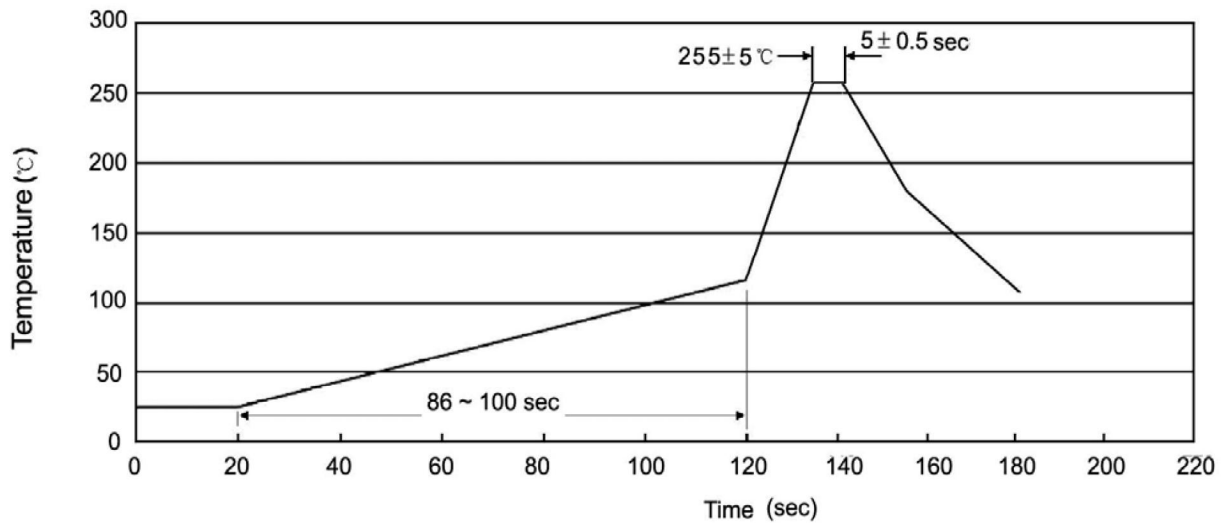
波峰焊温度曲线图(无铅) / Temperature Profile for Dip Soldering(Pb-Free)

说明：

- 1、预热温度 25 ~ 150°C，时间 60 ~ 90sec;
- 2、峰值温度 255±5°C，时间持续为 5±0.5sec;
- 3、焊接制程冷却速度为 2 ~ 10°C/sec.

Note:

- 1.Preheating:25~150°C, Time:60~90sec.
- 2.Peak Temp.:255±5°C, Duration:5±0.5sec.
3. Cooling Speed: 2~10°C/sec.

耐焊接热试验条件 / Resistance to Soldering Heat Test Conditions

温度：270±5°C

时间：10±1 sec.

Temp.:270±5°C

Time:10±1 sec

包装规格 / Packaging SPEC.

套管包装 / TUBE

Package Type 封装形式	Units 包装数量					Dimension 包装尺寸 (unit: mm ³)		
	Units/Tube 只/套管	Tubes/Inner Box 套管/盒	Units/Inner Box 只/盒	Inner Boxes/Outer Box 盒/箱	Units/Outer Box 只/箱	Tube 套管	Inner Box 盒	Outer Box 箱
TO-220FL	50	20	1,000	5	5,000	532×33×7.0	555×164×50	575×290×180

使用说明 / Notices